

**MOGALAKWENA LOCAL MUNICIPALITY**



**PROJECT NAME:  
APPOINTMENT OF A SERVICE PROVIDER FOR  
SUPPLY, DELIVERY, OFF-LOAD, INSTALLATION, COMMISSIONING AND  
SETTING OF 11KV & 33KV AUTO RECLOSERS FOR A PERIOD OF THREE  
YEARS.**

**TENDER NO: 31 -2023/2024**

**TENDER ADVERT DATE: 14 MARCH 2024**

**TENDER CLOSING DATE AND TIME: 15 APRIL 2024 AT 12:00p.m**

**NAME OF TENDERER:** \_\_\_\_\_

**TENDERED AMOUNT:** \_\_\_\_\_

**TENDER SUM IN WORDS:** \_\_\_\_\_

**CONTACT PERSON:** \_\_\_\_\_

**CELL NUMBER:** \_\_\_\_\_

**FAX NUMBER:** \_\_\_\_\_

**OFFICE NUMBER:** \_\_\_\_\_

**EMAIL ADDRESS:** \_\_\_\_\_

**POSTAL ADDRESS:** \_\_\_\_\_

**TENDER NO.**

**TENDER NOTICE AND INVITATION TO TENDER CLOSING TIME & DATE: 15  
APRIL 2024 AT 12:00p.m**

Mogalakwena Local Municipality hereby invites suitably qualified service providers to tender for the below mentioned project.

The details of the project are as follows:

No:	Project Name	COMPULSORY BRIEFING MEETING	Tender Number	Enquiries
1.	<b>PROJECT NAME: APPOINTMENT OF A SERVICE PROVIDER FOR SUPPLY, DELIVERY, OFF- LOAD AND INSTALLATION OF 11KV &amp; 33KV AUTORECLOSERS.</b>	NONE	31- 2023/2024	Supplychain@mogalakwena.gov.za @ 015 491 9662  Electrical Services @ 0154919646/9601

Mogalakwena Municipality will evaluate, adjudicate and award the bids in accordance with the PPPFA of 2022

**BID DOCUMENTS CONTAINING THE CONDITIONS OF BIDS AND REQUIREMENTS CAN BE DOWNLOADED ON E-TENDERS PUBLICATION PORTAL AT [www.etenders.gov.za](http://www.etenders.gov.za) for free and on [www.mogalakwena.gov.za](http://www.mogalakwena.gov.za).**

The respective project name with the project number must be clearly marked on the envelope before submission.

Complete tender documents, fully priced, signed and sealed in an envelope must be deposited in the Tender Box at Mogalakwena Municipality, 54 Retief Street, Mokopane, by no later than **15 April 2024 at 12:00p.m** for all the above projects.

*No late, faxed, telegraphic, emailed and telephonic tenders will be accepted. The council also reserves the right to negotiate further conditions and requirements with the successful tenderer.*

**NB\*** Service providers should take note that no bid/service will be awarded to a service provider who is not registered and valid on Web Based Central Supplier Database (CSD).

Enquiries related to this tender must be addressed to Electrical Department at 015 491 9649/9601.

The Municipality does not bind itself to accept the lowest or any tender and reserves the right to accept any tender or any part thereof, which may result in the acceptance of more than one tender, whichever the case may be.

**MM MALULEKA  
MUNICIPAL MANAGER  
54 RETIEF STREET  
MOKOPANE  
0601**

## **BIDDERS PLEASE NOTE THE FOLLOWING**

1. No late, faxed, telegraphic, emailed and telephonic tenders will be accepted. The council also reserves the right to negotiate further conditions and requirements with successful tenderer. Tenders received will be the basis for the contract negotiations and ultimately appointment of the suitable service provider. It is therefore important that service providers familiarise themselves with the municipality's processes and MLM supply chain management policy and to take them into account in preparing their tender.
2. Service Providers must note that the costs of preparing the tender and of negotiating the contract are not reimbursable and Mogalakwena Local Municipality is not bound to accept any of the tender submitted.
3. At any time before submission of the bid, Mogalakwena Local Municipality may, for any reason, whether at its own initiative or in response to a clarification requested by an invited firm, modify these Specifications by amendments. The amendment will be sent in writing by facsimile or electronic mail to all Service providers and will be binding on them. Mogalakwena Local Municipality may at its discretion extend the deadline for the submission of bids.

### **A. TENDER AMOUNT**

In preparing the tender amount, service providers are expected to consider the requirements and the conditions of these Specifications. The tender amount should include all costs associated with the project and relevant taxes. The tender amount must be a fixed cost and remain valid for **90 days** after the closing date of the tender submissions. The rate of exchange of this bid is not subject to any foreign currency and the price must be firm.

## **B. NEGOTIATIONS**

Negotiations to reach agreement on all points and sign a contract will be held at a time and place to be determined by Mogalakwena Local Municipality. Negotiations will include a discussion of the technical proposal, the proposed work plan, financial proposal/pricing and any suggestions made by the appointed service provider to improve the Terms of Reference. The agreed work plan, service level agreement and final Terms of Reference will then be incorporated into the "Description of Services" and form part of the contract.

## **C. SUBMISSION AND OPENING OF TENDER PROPOSAL**

The proposal tender document shall be placed in a sealed envelope clearly marked "project name, project number and the closing date". The envelope shall be deposited in the tender box at the Civic Centre situated at:

***54 Retief Street, MOKOPANE***

Note that any tender received after the closing date and time for submission, will not be considered.

***Technical Enquiries regarding the bid may be directed to:***

***Mr Manamela E at Electrical Services Telephone Number: (015) 491 9601/9646***

***Administrative Enquiries to Supply Chain Unit: -***

***supplychain@mogalakwena.gov.za Telephone number: -015 491 9662/9649***

The tenders will be opened immediately after the closing time for submission. At the opening all service providers' bids will be read aloud and the tender amount shall be made public and recorded.

Mogalakwena Local Municipality will take ownership of the outcomes and deliverables, thereby reserving the right to reproduce information from, copy and / or distribute such outcomes and deliverables without the prior consent of and / or reference to the service provider.

## SECTION 1: DETAILS

<b>Province</b>	<b>Limpopo</b>
<b>District</b>	<b>Waterberg</b>
<b>Municipality</b>	<b>Mogalakwena Local Municipality</b>
<b>Project</b>	<b>APPOINTMENT OF A SERVICE PROVIDER FOR SUPPLY, DELIVERY, OFF-LOAD AND INSTALLATION OF 11KV &amp; 33KV AUTORECLOSERS.</b>

## SECTION 2: EVALUATION CRITERIA

### STAGES OF EVALUATION

**Stage 1: Administrative**

**Stage 2: Functionality**

**Stage 3: Price and Specific goals**

#### **Stage 1: Administrative**

- Valid Tax Pin Certificate (For both Parties in case of a Joint Venture).
- Certified copy of company registration certificate.
- MBD Forms must be signed in black ink (no pencil is allowed or other colour)
- All MBD Forms must be completed and signed
- In case of a Joint Venture, Association or Consortium a formal contract agreement must be signed by both parties and be attached
- Any alterations on the proposals or the tender document must be initialled.
- Valid Proof of Residential, Municipal Rates and taxes OR Lease agreement with statement OR a dated stamped letter from tribal authority (Proof not more than three months old)
- The tenderer or any of its directors/shareholders is not listed on the Register of Tender Defaulters in terms of the Prevention of Combating of Corrupt Activities Act of 2004 as a person prohibited from doing business with the public sector.
- Central Supplier Database (CSD) report not older than three (03) months.
- Certified ID copies of all directors

## Stage 2: Functionality

The bid will be evaluated based on functionality as outline below:

Criteria	Weight	Score
<p><b>1. Company Experience:</b></p> <p><b>bidder must demonstrate experience in service providers for supply and installation of Auto-reclosers or Maintenance of HV network.</b></p> <p>Attach certified copies of orders with delivery notes, reference or appointment letters with formal institution logos and completion letter/certificate</p>	40	<p>5 or more orders with delivery notes, reference or appointment letters and completion letter/certificate=40 points.</p> <p>3- 4 orders with delivery notes, reference or appointment letters and completion letter/certificate = 25 points</p> <p>1- 2 orders with delivery notes, reference or appointment letters and completion letter/certificate = 15 Points</p>
<p><b>2. Project Team:</b></p> <p><b>Technicians / Electricians</b></p> <p><b>Attach CV and certified copies of your qualifications</b></p>	30	<p>Qualifications:</p> <p>Technicians with Diploma &amp; ECSA Registration (Electrical Engineering), =30</p> <p>Electricians with Diploma or N3 Certificate and Electrical Trade Test (Electrical Engineering), =20</p>
<p><b>3. Bank Rating</b></p> <p><b>NB: VETTING OF APPOINTMENT LETTERS FOR ALL BIDDERS MIGHT BE DONE AND NOTE INCORRECT INFO WILL IMMEDIATELY DISQUALIFIED</b></p>	10	<p>A=10 B=5 C &amp; D=3</p>
<p><b>4. List of Plant Owned (Valid certified copies of registration documents and road worthy certificate of crane truck in owner's name)</b></p> <p><b>or</b></p> <p><b>List of Plant Rental (Valid certified copies of registration documents and road worthy certificate of crane truck in the name of the lessor and a Letter of intent to lease)</b></p>	20	<p>2 - Cherry Picker trucks &amp; 2- 10 Ton Crane trucks =20</p> <p>1 - Cherry Picker truck &amp; 1 Crane Truck =10</p>
<b>TOTAL WEIGHT</b>	100	<b>100</b>

MINIMUM SCORE OBTAINABLE FOR FURTHER EVALUATION 80%

### SECTION 3: PRICING SCHEDULE

The Tenderer shall supply all the price information required in the price schedule, failure to do so shall invalidate the Tender.

The project cost must be inclusive of all chargeable costs to the municipality. The municipality will not pay any amount outside the projected/quoted amount. The municipality reserves the right to negotiate the project cost.

The successful service provider will be remunerated in accordance with Service Level Agreement.

#### PRICE SCHEDULE (BILL OF QUANTITIES)

(TENDERER MUST INDICATE THE CURRENCY OF THE OFFER PRICE)

No.	Description	Quantity	Material	Installation	Total price
1	AUTORECLOSER 11KV	20			
2	AUTORECLOSER 33KV	10			
<b>Sub Total</b>					
<b>VAT</b>					
<b>GRAND TOTAL</b>					



## **SPECIFICATIONS**

### **BACKGROUND**

The Mogalakwena Local Municipality (MLM) wishes to appoint a **SERVICE PROVIDER FOR SUPPLY, DELIVERY, OFF-LOAD AND INSTALLATION OF 11KV & 33KV AUTO-RECLOSERS.**

### **11KV & 33KV AUTO-RECLOSER STANDARD SPECIFICATIONS**

#### **A. TECHNICAL SPECIFICATION**

##### **1. Environmental Conditions:**

The reclosures will be used on an 11KV and 33KV overhead lines system in an area with severe lightning storms. The ambient temperature rises to 40°c and the number of sunshine days is high. Equipment offered shall therefore preferably have a BIL of 150Kv and shall be resistant to high temperature and ultra violet radiation.

##### **2. System Particulars**

The reclosures shall have vacuum contacts rated to carry a load current of 400A-800Amperes continuously in an ambient temperature of 40°c. The rated fault current shall be at least 12.5KA. The reclosures shall have a lightning impulse withstand voltage of at least 125kv.

##### **3. Equipment Requirements:**

The reclosures shall comply with the relevant provisions of NRS-036 as amended. Reclosures with programmable trip curves and selectable number of reclosures are required. Separate trip curves for phase faults and earth faults are required.

##### **4. Descriptive Literature:**

Tenders shall submit descriptive literature with their tenders. Full electrical and constructional details shall be submitted, and completeness of this data will have a bearing on the adjudication of the tenders.

##### **5. Guarantee:**

Tenderers shall state full particulars of the guarantee offered.

##### **6. Maintenance:**

Tenderers shall state their capability to supply spares for the recloser in future. A complete maintenance manual shall be included. Maintenance and repairs must be

able to be done by the municipal technicians in the municipal electrical workshop.  
The successful bidder must submit training on the above

## **1. Material Type of the Product**

The entire product to be provided must be S.A.B.S APPROVED and be of the highest quality.

### **Main**

Range of product E series

Product or component type Recloser

[Icm] rated short-circuit making

Capacity

12.5 kA RMS voltage

32.5 kA peak

16 kA RMS voltage

41.6 kA peak

Complementary

Operating time 0.1 s closing

0.05 s opening

Mechanical durability 10000 cycles

10000 cycles full load

Breaking capacity 12.5 kA

16 kA

Charging current 25 A cable charging

5 A line charging

40 A cable charging

Rated short-duration power frequency withstand voltage

60...70 kV phase to earth

60...70 kV across interrupter

Environment

Environmental characteristic Solar radiation 1.1 kW/m<sup>2</sup>

Ambient air temperature for operation -40...50 °C

Relative humidity 0...100 %

## **2. General**

- Bidders are requested to quote firm prices.
- The pricing shall be fixed for one year thereafter price increases are to be negotiated when the needs arise
- The period, for which these prices shall be effective, together with the dates of the future annual reviews and their notice shall be shown.
- All service providers will be requested to deliver the goods to Mogalakwena Local Municipality main store
- No goods will be allowed to be delivered on site unless special approval of the head of the department has been approved.
- All goods that are delivered at stores must be accompanied by a delivery note.

- All delivery of goods must be properly packed and marked clearly with proper description of the item.
- **ALL ITEMS MUST BE PRICED, FAILURE TO DO THAT WILL AUTOMATICALLY INVALIDATE YOUR BID**

Each quotation shall be accompanied by such drawings and training of our technicians/electricians, as the tenderer considers necessary to describe adequately the various items of the equipment offered.

In the event of a firm order being placed, a complete schematic diagram and a diagram showing the foundations required, must be approved by the electrical engineer before manufacturing commences.

### **Price Assessment**

Proposal will be evaluated based on the PPPFA 80/20-point system.

The 80/20-point system for acquisition of goods and services for Rand value equal to or above R30 000 and up to R 50 Million will be as follows:

<b>Historically Disadvantaged Individuals - HDI</b>	<b>80/20 Preferential Point System</b>	<b>90/10 Preferential Point System</b>	<b>Means of Verification</b>
	<b>20</b>	<b>10</b>	
<b>Race – people who are Black, Coloured or Indian</b>	<b>6</b>	<b>3</b>	<b>CSD report and Certified Copy of Identification Documentation</b>
<b>Local Economic Development</b>	<b>4</b>	<b>2</b>	<b>Company head office residence within Mogalakwena Municipal Jurisdiction as per CSD and proof of residence</b>
<b>Gender - Women</b>	<b>3</b>	<b>1</b>	<b>CSD report and Certified Copy of Identification Documentation</b>
<b>Youth</b>	<b>4</b>	<b>2</b>	<b>CSD report and Certified Copy of Identification Documentation</b>

<b>Disability</b>	<b>3</b>	<b>2</b>	<b>Certified copy of Doctor's Certificate with medical practice number</b>
-------------------	----------	----------	--

	<b>SCORES</b>
<b>Price Assessment</b>	<b>80</b>
<b>TOTAL</b>	<b>80</b>

<b>SPECIFIC GOALS POINTS</b>	<b>20</b>
------------------------------	-----------

**MBD FORMS**

---

MBD 1

INVITATION TO BID

---

YOU ARE HEREBY INVITED TO BID FOR REQUIREMENTS OF THE (NAME OF MUNICIPALITY/ENTITY)

BID NUMBER: ..... CLOSING DATE: ..... CLOSING TIME: .....

DESCRIPTION.....  
.....

---

**The successful bidder will be required to fill in and sign a written Contract Form ( MBD 7).**

---

BID DOCUMENTS MAY BE POSTED TO:

.....  
.....

**OR**

DEPOSITED IN THE BID BOX SITUATED AT (STREET ADDRESS)

.....

.....

.....

.....

Bidders should ensure that bids are delivered timeously to the correct address. If the bid is late, it will not be accepted for consideration.

The bid box is generally open 24 hours a day, 7 days a week.

ALL BIDS MUST BE SUBMITTED ON THE OFFICIAL FORMS – (NOT TO BE RE-TYPED)

THIS BID IS SUBJECT TO THE PREFERENTIAL PROCUREMENT POLICY FRAMEWORK ACT AND THE PREFERENTIAL PROCUREMENT REGULATIONS, 2017, THE GENERAL CONDITIONS OF CONTRACT (GCC) AND, IF APPLICABLE, ANY OTHER SPECIAL CONDITIONS OF CONTRACT

**NB: NO BIDS WILL BE CONSIDERED FROM PERSONS IN THE SERVICE OF THE STATE (as defined in Regulation 1 of the Local Government: Municipal Supply Chain Management Regulations)**

**THE FOLLOWING PARTICULARS MUST BE FURNISHED  
(FAILURE TO DO SO MAY RESULT IN YOUR BID BEING DISQUALIFIED)**

NAME OF BIDDER

.....  
.....

POSTAL ADDRESS

.....  
.....

STREET ADDRESS

.....  
.....

TELEPHONE NUMBER

CODE.....NUMBER.....

.....

CELLPHONE NUMBER

.....  
.....

FACSIMILE NUMBER

CODE

.....  
NUMBER.....

E-MAIL ADDRESS

.....  
.....

VAT REGISTRATION NUMBER

.....  
.....

HAS AN ORIGINAL AND VALID TAX CLEARANCE CERTIFICATE BEEN  
ATTACHED? (MBD 2) YES/NO

HAS A B-BBEE STATUS LEVEL VERIFICATION CERTIFICATE BEEN SUBMITTED? (MBD 6.1) YES/NO

IF YES, WHO WAS THE CERTIFICATE ISSUED BY?

AN ACCOUNTING OFFICER AS CONTEMPLATED IN THE CLOSE CORPORATION ACT (CCA)

A VERIFICATION AGENCY ACCREDITED BY THE SOUTH AFRICAN NATIONAL ACCREDITATION SYSTEM (SANAS)

A REGISTERED AUDITOR

(Tick applicable box)

**(A B-BBEE STATUS LEVEL VERIFICATION CERTIFICATE MUST BE SUBMITTED IN ORDER TO QUALIFY FOR PREFERENCE POINTS FOR B-BBEE)**

ARE YOU THE ACCREDITED REPRESENTATIVE IN SOUTH AFRICA FOR THE GOODS/SERVICES/WORKS OFFERED

YES/NO  
(IF

YES ENCLOSE PROOF)

SIGNATURE OF BIDDER

.....  
.....

DATE

.....  
.....

CAPACITY UNDER WHICH THIS BID IS SIGNED

.....  
.....

TOTAL BID PRICE..... TOTAL NUMBER OF ITEMS OFFERED .....

**ANY ENQUIRIES REGARDING THE BIDDING PROCEDURE MAY BE DIRECTED TO:**

**Municipality / Municipal Entity:**

.....



**Department:**

.....

**Contact**

**Person:**

.....

**Tel:**

.....

.....

**Fax:**

.....

**ANY ENQUIRIES REGARDING TECHNICAL INFORMATION MAY BE DIRECTED  
TO:**

**Contact**

**Person:**

.....

**Tel:**

.....

.....

**Fax:**

.....

## **MBD 2**

### **TAX CLEARANCE CERTIFICATE REQUIREMENTS**

**It is a condition of bid that the taxes of the successful bidder must be in order, or that satisfactory arrangements have been made with South African Revenue Service (SARS) to meet the bidder's tax obligations.**

**1 In order to meet this requirement bidders are required to complete in full the attached form TCC 001 "Application for a Tax Clearance Certificate" and submit it to any SARS branch office nationally. The Tax Clearance Certificate Requirements are also applicable to foreign bidders / individuals who wish to submit bids.**

**2 SARS will then furnish the bidder with a Tax Clearance Certificate that will be valid for a period of 1 (one) year from the date of approval.**

**3 The original Tax Clearance Certificate must be submitted together with the bid. Failure to submit the original and valid Tax Clearance Certificate will result in the invalidation of the bid. Certified copies of the Tax Clearance Certificate will not be acceptable.**

**4 In bids where Consortia / Joint Ventures / Sub-contractors are involved, each party must submit a separate Tax Clearance Certificate.**

**5 Copies of the TCC 001 "Application for a Tax Clearance Certificate" form are available from any SARS branch office nationally or on the website [www.sars.gov.za](http://www.sars.gov.za).**

**6 Applications for the Tax Clearance Certificates may also be made via eFiling. In order to use this provision, taxpayers will need to register with SARS as eFilers through the website [www.sars.gov.za](http://www.sars.gov.za).**

**MBD 4**

**DECLARATION OF INTEREST**

1. No bid will be accepted from persons in the service of the state<sup>1</sup>.
2. Any person, having a kinship with persons in the service of the state, including a blood relationship, may make an offer or offers in terms of this invitation to bid. In view of possible allegations of favouritism, should the resulting bid, or part thereof, be awarded to persons connected with or related to persons in service of the state, it is required that the bidder or their authorised representative declare their position in relation to the evaluating/adjudicating authority.

3 In order to give effect to the above, the following questionnaire must be completed and submitted with the bid.

3.1 Full Name of bidder or his or her representative:.....

3.2 Identity Number:  
.....

3.3 Position occupied in the Company (director, trustee, shareholder<sup>2</sup>):.....

3.4 Company Registration Number:  
.....

3.5 Tax Reference Number:.....

3.6 VAT Registration Number:  
.....

3.7 The names of all directors / trustees / shareholders members, their individual identity numbers and state employee numbers must be indicated in paragraph 4 below.

3.8 Are you presently in the service of the state? **YES / NO**

3.8.1 If yes, furnish particulars.

.....  
.....  
.....

<sup>1</sup>MSCM Regulations: “in the service of the state” means to be –

- (a) a member of –
  - (i) any municipal council;
  - (ii) any provincial legislature; or
  - (iii) the national Assembly or the national Council of provinces;
- (b) a member of the board of directors of any municipal entity;
- (c) an official of any municipality or municipal entity;
- (d) an employee of any national or provincial department, national or provincial public entity or constitutional institution within the meaning of the Public Finance Management Act, 1999 (Act No.1 of 1999);
- (e) a member of the accounting authority of any national or provincial public entity; or
- (f) an employee of Parliament or a provincial legislature.

<sup>2</sup> Shareholder” means a person who owns shares in the company and is actively involved in the management of the company or business and exercises control over the company.

3.9 Have you been in the service of the state for the past twelve months?  
..... **YES / NO**

3.9.1 If yes, furnish particulars.....  
.....

3.10 Do you have any relationship (family, friend, other) with persons in the service of the state and who may be involved with the evaluation and or adjudication of this bid? ..... **YES / NO**

3.10.1 If yes, furnish particulars.  
.....  
.....

3.11 Are you, aware of any relationship (family, friend, other) between any other bidder and any persons in the service of the state who may be involved with the evaluation and or adjudication of this bid?  
**YES / NO**

3.11.1 If yes, furnish particulars

.....  
.....

3.12 Are any of the company's directors, trustees, managers, principle shareholders or stakeholders in service of the state? **YES / NO**

3.12.1 If yes, furnish particulars.

.....  
.....

3.13 Are any spouse, child or parent of the company's directors trustees, managers, principle shareholders or stakeholders in service of the state? **YES / NO**

3.13.1 If yes, furnish particulars.

.....  
.....

3.14 Do you or any of the directors, trustees, managers, principle shareholders, or stakeholders of this company have any interest in any other related companies or business whether or not they are bidding for this contract.

**YES / NO**

3.14.1 If yes, furnish particulars:

.....  
.....

4. Full details of directors / trustees / members / shareholders.

Full Name	Identity Number	State Employee Number

.....  
**Signature**

.....  
**Date**

.....  
**Capacity**

.....  
**Name of Bidder**

**DECLARATION FOR PROCUREMENT ABOVE R10 MILLION (ALL APPLICABLE TAXES INCLUDED)**

For all procurement expected to exceed R10 million (all applicable taxes included), bidders must complete the following questionnaire:

1 Are you by law required to prepare annual financial statements for auditing? .....

1.1 If yes, submit audited annual financial statements for the past three years or since the date of establishment if established during the past three years.

.....  
.....  
.....  
.....  
.....

\* Delete if not applicable

**\*YES /NO**

2 Do you have any outstanding undisputed commitments for municipal services towards any municipality for more than three months or any other service provider in respect of which payment is overdue for more than 30 days?

2.1 If no, this serves to certify that the bidder has no undisputed commitments for municipal services towards any municipality for more than three months or other service provider in respect of which payment is overdue for more than 30 days.

**\*YES / NO**

2.2 If yes, provide particulars.

3

4 Has any contract been awarded to you by an organ of state during the past five years, including particulars of any material noncompliance or dispute concerning the execution of such contract?

3.1 If yes, furnish particulars

.....

..... **\*YES / NO**



4. Will any portion of goods or services be sourced from outside **\*YES / NO**

the Republic, and, if so, what portion and whether any portion of payment from the municipality / municipal entity is expected to be transferred out of the Republic?

4.1 If yes, furnish particulars

.....  
.....

**CERTIFICATION**

**I, THE UNDERSIGNED (NAME)**

.....

**CERTIFY THAT THE INFORMATION FURNISHED ON THIS DECLARATION FORM IS CORRECT.**

**I ACCEPT THAT THE STATE MAY ACT AGAINST ME SHOULD THIS DECLARATION PROVE TO BE FALSE.**

.....

Signature

.....

Date

.....

Position

Name of Bidder

**PREFERENCE POINTS CLAIM FORM IN TERMS OF THE PREFERENTIAL PROCUREMENT REGULATIONS 2022**

This preference form must form part of all tenders invited. It contains general information and serves as a claim form for preference points for specific goals.

**NB: BEFORE COMPLETING THIS FORM, TENDERERS MUST STUDY THE GENERAL CONDITIONS, DEFINITIONS AND DIRECTIVES APPLICABLE IN RESPECT OF THE TENDER AND PREFERENTIAL PROCUREMENT REGULATIONS, 2022**

**1. GENERAL CONDITIONS**

1.1 The following preference point systems are applicable to invitations to tender:

- the 80/20 system for requirements with a Rand value of up to R50 000 000 (all applicable taxes included); and
- the 90/10 system for requirements with a Rand value above R50 000 000 (all applicable taxes included).

**1.2 To be completed by the organ of state**

*(delete whichever is not applicable for this tender).*

- a) The applicable preference point system for this tender is the **90/10** preference point system.
- b) The applicable preference point system for this tender is the **80/20** preference point system.
- c) Either the **90/10 or 80/20 preference point system** will be applicable in this tender. The lowest/ highest acceptable tender will be used to determine the accurate system once tenders are received.

1.3 Points for this tender (even in the case of a tender for income-generating contracts) shall be awarded for:

- (a) Price; and
- (b) Specific Goals.

**1.4 To be completed by the organ of state:**

The maximum points for this tender are allocated as follows:

	POINTS
<b>PRICE</b>	<b>80</b>
<b>SPECIFIC GOALS</b>	<b>20</b>
<b>Total points for Price and SPECIFIC GOALS</b>	<b>100</b>

- 1.5 Failure on the part of a tenderer to submit proof or documentation required in terms of this tender to claim points for specific goals with the tender, will be interpreted to mean that preference points for specific goals are not claimed.
- 1.6 The organ of state reserves the right to require of a tenderer, either before a tender is adjudicated or at any time subsequently, to substantiate any claim in regard to preferences, in any manner required by the organ of state.

**2. DEFINITIONS**

- (a) “**tender**” means a written offer in the form determined by an organ of state in response to an invitation to provide goods or services through price quotations, competitive tendering process or any other method envisaged in legislation;
- (b) “**price**” means an amount of money tendered for goods or services, and includes all applicable taxes less all unconditional discounts;
- (c) “**rand value**” means the total estimated value of a contract in Rand, calculated at the time of bid invitation, and includes all applicable taxes;
- (d) “**tender for income-generating contracts**” means a written offer in the form determined by an organ of state in response to an invitation for the origination of income-generating contracts through any method envisaged in legislation that will result in a legal agreement between the organ of state and a third party that produces revenue for the organ of state, and includes, but is not limited to, leasing and disposal of assets and concession contracts, excluding direct sales and disposal of assets through public auctions; and
- (e) “**the Act**” means the Preferential Procurement Policy Framework Act, 2000 (Act No. 5 of 2000).

**3. FORMULAE FOR PROCUREMENT OF GOODS AND SERVICES**

**3.1. POINTS AWARDED FOR PRICE**

**3.1.1 THE 80/20 OR 90/10 PREFERENCE POINT SYSTEMS**

A maximum of 80 or 90 points is allocated for price on the following basis:

$$\begin{array}{ccc}
 \mathbf{80/20} & \mathbf{or} & \mathbf{90/10} \\
 \\
 \mathbf{P_s = 80 \left( 1 - \frac{P_t - P_{min}}{P_{min}} \right)} & \mathbf{or} & \mathbf{P_s = 90 \left( 1 - \frac{P_t - P_{min}}{P_{min}} \right)}
 \end{array}$$

Where

- P<sub>s</sub> = Points scored for price of tender under consideration
- P<sub>t</sub> = Price of tender under consideration
- P<sub>min</sub> = Price of lowest acceptable tender

### 3.2. FORMULAE FOR DISPOSAL OR LEASING OF STATE ASSETS AND INCOME GENERATING PROCUREMENT

#### 3.2.1. POINTS AWARDED FOR PRICE

A maximum of 80 or 90 points is allocated for price on the following basis:

$$Ps = 80 \left( 1 + \frac{Pt - Pmax}{Pmax} \right) \text{ or } Ps = 90 \left( 1 + \frac{Pt - Pmax}{Pmax} \right)$$

Where

- Ps = Points scored for price of tender under consideration  
Pt = Price of tender under consideration  
Pmax = Price of highest acceptable tender

### 4. POINTS AWARDED FOR SPECIFIC GOALS

- 4.1. In terms of Regulation 4(2); 5(2); 6(2) and 7(2) of the Preferential Procurement Regulations, preference points must be awarded for specific goals stated in the tender. For the purposes of this tender the tenderer will be allocated points based on the goals stated in table 1 below as may be supported by proof/ documentation stated in the conditions of this tender:
- 4.2. In cases where organs of state intend to use Regulation 3(2) of the Regulations, which states that, if it is unclear whether the 80/20 or 90/10 preference point system applies, an organ of state must, in the tender documents, stipulate in the case of—
- (a) an invitation for tender for income-generating contracts, that either the 80/20 or 90/10 preference point system will apply and that the highest acceptable tender will be used to determine the applicable preference point system; or
  - (b) any other invitation for tender, that either the 80/20 or 90/10 preference point system will apply and that the lowest acceptable tender will be used to determine the applicable preference point system,

then the organ of state must indicate the points allocated for specific goals for both the 90/10 and 80/20 preference point system.

**Table 1: Specific goals for the tender and points claimed are indicated per the table below.**

*(Note to organs of state: Where either the 90/10 or 80/20 preference point system is applicable, corresponding points must also be indicated as such.*

*Note to tenderers: The tenderer must indicate how they claim points for each preference point system.)*

The specific goals allocated points in terms of this tender	Number of points allocated (90/10 system) (To be completed by the organ of state)	Number of points allocated (80/20 system) (To be completed by the organ of state)	Number of points claimed (90/10 system) (To be completed by the tenderer)	Number of points claimed (80/20 system) (To be completed by the tenderer)
Enterprises located in the district municipal area		20		

**DECLARATION WITH REGARD TO COMPANY/FIRM**

4.3. Name of company/firm.....

4.4. Company registration number: .....

4.5. TYPE OF COMPANY/ FIRM

- Partnership/Joint Venture / Consortium
- One-person business/sole propriety
- Close corporation
- Public Company
- Personal Liability Company
- (Pty) Limited
- Non-Profit Company
- State Owned Company

[TICK APPLICABLE BOX]

4.6. I, the undersigned, who is duly authorised to do so on behalf of the company/firm, certify that the points claimed, based on the specific goals as advised in the tender, qualifies the company/ firm for the preference(s) shown and I acknowledge that:

- i) The information furnished is true and correct;

- ii) The preference points claimed are in accordance with the General Conditions as indicated in paragraph 1 of this form;
- iii) In the event of a contract being awarded as a result of points claimed as shown in paragraphs 1.4 and 4.2, the contractor may be required to furnish documentary proof to the satisfaction of the organ of state that the claims are correct;
- iv) If the specific goals have been claimed or obtained on a fraudulent basis or any of the conditions of contract have not been fulfilled, the organ of state may, in addition to any other remedy it may have –
  - (a) disqualify the person from the tendering process;
  - (b) recover costs, losses or damages it has incurred or suffered as a result of that person’s conduct;
  - (c) cancel the contract and claim any damages which it has suffered as a result of having to make less favourable arrangements due to such cancellation;
  - (d) recommend that the tenderer or contractor, its shareholders and directors, or only the shareholders and directors who acted on a fraudulent basis, be restricted from obtaining business from any organ of state for a period not exceeding 10 years, after the *audi alteram partem* (hear the other side) rule has been applied; and
  - (e) forward the matter for criminal prosecution, if deemed necessary.

.....

**SIGNATURE(S) OF TENDERER(S)**

**SURNAME AND NAME:** .....

**DATE:** .....

**ADDRESS:** .....

.....

.....

.....

## **DECLARATION CERTIFICATE FOR LOCAL PRODUCTION AND CONTENT FOR DESIGNATED SECTORS**

This Municipal Bidding Document (MBD) must form part of all bids invited. It contains general information and serves as a declaration form for local content (local production and local content are used interchangeably).

Before completing this declaration, bidders must study the General Conditions, Definitions, Directives applicable in respect of Local Content as prescribed in the Preferential Procurement Regulations, 2022, the South African Bureau of Standards (SABS) approved technical specification number SATS 1286:2011 (Edition 1) and the Guidance on the Calculation of Local Content together with the Local Content Declaration Templates [Annex C (Local Content Declaration: Summary Schedule), D (Imported Content Declaration: Supporting Schedule to Annex C) and E (Local Content Declaration: Supporting Schedule to Annex C)].

### **1. General Conditions**

- 1.1. Preferential Procurement Regulations, 2017 (Regulation 8) make provision for the promotion of local production and content.
- 1.2. Regulation 8.(2) prescribes that in the case of designated sectors, organs of state must advertise such tenders with the specific bidding condition that only locally produced or manufactured goods, with a stipulated minimum threshold for local production and content will be considered.
- 1.3. Where necessary, for tenders referred to in paragraph 1.2 above, a two - stage bidding process may be followed, where the first stage involves a minimum threshold for local production and content and the second stage price and specific goals.
- 1.4. A person awarded a contract in relation to a designated sector, may not sub-contract in such a manner that the local production and content of the overall value of the contract is reduced to below the stipulated minimum threshold.
- 1.5. The local content (LC) expressed as a percentage of the bid price must be calculated in accordance with the SABS approved technical specification number SATS 1286: 2011 as follows:

$$LC = [1 - \frac{x}{y}] * 100$$

Where  $x$  is the imported content in Rand  
 $y$  is the bid price in Rand excluding value added tax (VAT)

Prices referred to in the determination of x must be converted to Rand (ZAR) by using the exchange rate published by South African Reserve Bank (SARB) on the date of advertisement of the bid as indicated in paragraph 3.1 below.

**The SABS approved technical specification number SATS 1286:2011 is accessible on [http://www.thedti.gov.za/industrial development/ip.jsp](http://www.thedti.gov.za/industrial%20development/ip.jsp) at no cost.**

1.6. A bid may be disqualified if this Declaration Certificate and the Annex C (Local Content Declaration: Summary Schedule) are not submitted as part of the bid documentation;

**2. The stipulated minimum threshold(s) for local production and content (refer to Annex A of SATS 1286:2011) for this bid is/are as follows:**

<u>Description of services, works or goods</u>	<u>Stipulated minimum threshold</u>
_____	_____ %
_____	_____ %
_____	_____ %

3. Does any portion of the goods or services offered have any imported content?  
(Tick applicable box)

YES		NO	
-----	--	----	--

3.1. If yes, the rate(s) of exchange to be used in this bid to calculate the local content as prescribed in paragraph 1.5 of the general conditions must be the rate(s) published by SARB for the specific currency on the date of advertisement of the bid.

The relevant rates of exchange information is accessible on [www.resbank.co.za](http://www.resbank.co.za)

Indicate the rate(s) of exchange against the appropriate currency in the table below (refer to Annex A of SATS 1286:2011):

<b>Currency</b>	<b>Rates of exchange</b>
US Dollar	
Pound Sterling	
Euro	
Yen	
Other	

NB: Bidders must submit proof of the SARB rate (s) of exchange used.



4. Where, after the award of a bid, challenges are experienced in meeting the stipulated minimum threshold for local content the dti must be informed accordingly in order for the dti to verify and in consultation with the AO/AA provide directives in this regard.

**LOCAL CONTENT DECLARATION**  
**(REFER TO ANNEX B OF SATS 1286:2011)**

**LOCAL CONTENT DECLARATION BY CHIEF FINANCIAL OFFICER OR OTHER LEGALLY RESPONSIBLE PERSON NOMINATED IN WRITING BY THE CHIEF EXECUTIVE OR SENIOR MEMBER/PERSON WITH MANAGEMENT RESPONSIBILITY (CLOSE CORPORATION, PARTNERSHIP OR INDIVIDUAL)**

**IN RESPECT OF BID NO.** .....

**ISSUED BY:** (Procurement Authority / Name of Institution):  
 .....

NB

- 1 The obligation to complete, duly sign and submit this declaration cannot be transferred to an external authorized representative, auditor or any other third party acting on behalf of the bidder.
- 2 Guidance on the Calculation of Local Content together with Local Content Declaration Templates (Annex C, D and E) is accessible on [http://www.thedti.gov.za/industrial\\_development/ip.jsp](http://www.thedti.gov.za/industrial_development/ip.jsp). Bidders should first complete Declaration D. After completing Declaration D, bidders should complete Declaration E and then consolidate the information on Declaration C. **Declaration C should be submitted with the bid documentation at the closing date and time of the bid in order to substantiate the declaration made in paragraph (c) below.** Declarations D and E should be kept by the bidders for verification purposes for a period of at least 5 years. The successful bidder is required to continuously update Declarations C, D and E with the actual values for the duration of the contract.

I, the undersigned, ..... (full names),  
do hereby declare, in my capacity as .....  
of .....(name of bidder  
entity), the following:

- (a) The facts contained herein are within my own personal knowledge.
- (b) I have satisfied myself that:
  - (i) the goods/services/works to be delivered in terms of the above-specified bid comply with the minimum local content requirements as specified in the bid, and as measured in terms of SATS 1286:2011; and
- (c) The local content percentage (%) indicated below has been calculated using the formula given in clause 3 of SATS 1286:2011, the rates of exchange indicated in paragraph 3.1 above and the information contained in Declaration D and E which has been consolidated in Declaration C:

Bid price, excluding VAT (y)	R
Imported content (x), as calculated in terms of SATS 1286:2011	R
Stipulated minimum threshold for local content (paragraph 3 above)	
Local content %, as calculated in terms of SATS 1286:2011	

**If the bid is for more than one product, the local content percentages for each product contained in Declaration C shall be used instead of the table above. The local content percentages for each product has been calculated using the formula given in clause 3 of SATS 1286:2011, the rates of exchange indicated in paragraph 3.1 above and the information contained in Declaration D and E.**

- (d) I accept that the Procurement Authority / Institution has the right to request that the local content be verified in terms of the requirements of SATS 1286:2011.
- (e) I understand that the awarding of the bid is dependent on the accuracy of the information furnished in this application. I also understand that the submission of incorrect data, or data that are not verifiable as described in SATS 1286:2011, may result in the Procurement Authority / Institution imposing any or all of the remedies as provided for in Regulation 14 of the Preferential Procurement Regulations, 2022 promulgated under the Preferential Policy Framework Act (PPFA), 2000 (Act No. 5 of 2000).

**SIGNATURE:** \_\_\_\_\_

**WITNESS No. 1** \_\_\_\_\_

**DATE:** \_\_\_\_\_

**WITNESS No. 2** \_\_\_\_\_

**DATE:** \_\_\_\_\_

**CONTRACT FORM - PURCHASE OF GOODS/WORKS**

**THIS FORM MUST BE FILLED IN DUPLICATE BY BOTH THE SUCCESSFUL BIDDER (PART 1) AND THE PURCHASER (PART 2). BOTH FORMS MUST BE SIGNED IN THE ORIGINAL SO THAT THE SUCCESSFUL BIDDER AND THE PURCHASER WOULD BE IN POSSESSION OF ORIGINALLY SIGNED CONTRACTS FOR THEIR RESPECTIVE RECORDS.**

**PART 1 (TO BE FILLED IN BY THE BIDDER)**

1. I hereby undertake to supply all or any of the goods and/or works described in the attached bidding documents to (name of institution) ..... in accordance with the requirements and specifications stipulated in bid number..... at the price/s quoted. My offer/s remain binding upon me and open for acceptance by the purchaser during the validity period indicated and calculated from the closing time of bid.
  
2. The following documents shall be deemed to form and be read and construed as part of this agreement:
  - (i) Bidding documents, *viz*
    - Invitation to bid;
    - Tax clearance certificate;
    - Pricing schedule(s);
    - Technical Specification(s);
    - Preference claims for Broad Based Black Economic Empowerment Status Level of Contribution in terms of the Preferential Procurement Regulations 2011;
    - Declaration of interest;
    - Declaration of bidder's past SCM practices;
    - Certificate of Independent Bid Determination;
    - Special Conditions of Contract;
  - (ii) General Conditions of Contract; and
  - (iii) Other (specify)
  
3. I confirm that I have satisfied myself as to the correctness and validity of my bid; that the price(s) and rate(s) quoted cover all the goods and/or works specified in the bidding documents; that the price(s) and rate(s) cover all my obligations and I accept that any mistakes regarding price(s) and rate(s) and calculations will be at my own risk.

4. I accept full responsibility for the proper execution and fulfilment of all obligations and conditions devolving on me under this agreement as the principal liable for the due fulfilment of this contract.
5. I declare that I have no participation in any collusive practices with any bidder or any other person regarding this or any other bid.
6. I confirm that I am duly authorised to sign this contract.

NAME (PRINT)

.....

CAPACITY

.....

SIGNATURE

.....

NAME OF FIRM

.....

DATE

.....

WITNESSES

1

.....

2.

.....

DATE:

**CONTRACT FORM - PURCHASE OF GOODS/WORKS**

**PART 2 (TO BE FILLED IN BY THE PURCHASER)**

- 1. I..... in my capacity as..... accept your bid under reference number .....dated.....for the supply of goods/works indicated hereunder and/or further specified in the annexure(s).
- 2. An official order indicating delivery instructions is forthcoming.
- 3. I undertake to make payment for the goods/works delivered in accordance with the terms and conditions of the contract, within 30 (thirty) days after receipt of an invoice accompanied by the delivery note.

<b>ITEM NO.</b>	<b>PRICE (ALL APPLICABLE TAXES INCLUDED)</b>	<b>BRAND</b>	<b>DELIVERY PERIOD</b>	<b>B-BBEE STATUS LEVEL OF CONTRIBUTION</b>	<b>MINIMUM THRESHOLD FOR LOCAL PRODUCTION AND CONTENT (if applicable)</b>

4. I confirm that I am duly authorized to sign this contract.

SIGNED AT .....ON.....

NAME (PRINT) .....

SIGNATURE .....

OFFICIAL STAMP

WITNESSES

1. ....

2. ....

DATE .....

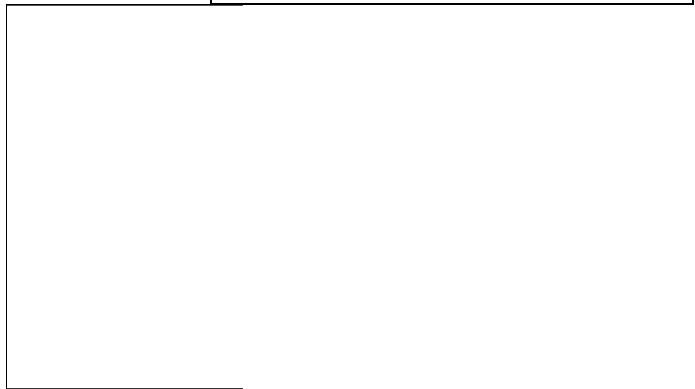

**CONTRACT FORM - RENDERING OF SERVICES**

**THIS FORM MUST BE FILLED IN DUPLICATE BY BOTH THE SERVICE PROVIDER (PART 1) AND THE PURCHASER (PART 2). BOTH FORMS MUST BE SIGNED IN THE ORIGINAL SO THAT THE SERVICE PROVIDER AND THE PURCHASER WOULD BE IN POSSESSION OF ORIGINALLY SIGNED CONTRACTS FOR THEIR RESPECTIVE RECORDS.**

**PART 1 (TO BE FILLED IN BY THE SERVICE PROVIDER)**

7. I hereby undertake to render services described in the attached bidding documents to (name of the institution)..... in accordance with the requirements and task directives / proposals specifications stipulated in Bid Number..... at the price/s quoted. My offer/s remain binding upon me and open for acceptance by the Purchaser during the validity period indicated and calculated from the closing date of the bid.
  
8. The following documents shall be deemed to form and be read and construed as part of this agreement:
  - (iv) Bidding documents, viz
    - Invitation to bid;
    - Tax clearance certificate;
    - Pricing schedule(s);
    - Filled in task directive/proposal;
    - Preference claims for Broad Based Black Economic Empowerment Status Level of Contribution in terms of the Preferential Procurement Regulations 2011;
    - Declaration of interest;
    - Declaration of Bidder's past SCM practices;
    - Certificate of Independent Bid Determination;
    - Special Conditions of Contract;
  - (v) General Conditions of Contract; and
  - (vi) Other (specify)
  
9. I confirm that I have satisfied myself as to the correctness and validity of my bid; that the price(s) and rate(s) quoted cover all the services specified in the bidding documents; that the price(s) and rate(s) cover all my obligations and I accept that any mistakes regarding price(s) and rate(s) and calculations will be at my own risk.

10. I accept full responsibility for the proper execution and fulfilment of all obligations and conditions devolving on me under this agreement as the principal liable for the due fulfillment of this contract.
11. I declare that I have no participation in any collusive practices with any bidder or any other person regarding this or any other bid.
12. I confirm that I am duly authorised to sign this contract.

<p>NAME (PRINT) .....</p> <p>CAPACITY .....</p> <p>SIGNATURE .....</p> <p>NAME OF FIRM .....</p> <p>DATE .....</p>	<p>.....</p>	<p>WITNESSES</p> <p>1 .....</p> <p>.....</p> <p>2 .....</p>
--	--------------	---



**CONTRACT FORM - RENDERING OF SERVICES**  
**PART 2 (TO BE FILLED IN BY THE PURCHASER)**

- 4. I..... in my capacity as..... accept your bid under reference number .....dated.....for the rendering of services indicated hereunder and/or further specified in the annexure(s).
- 5. An official order indicating service delivery instructions is forthcoming.
- 6. I undertake to make payment for the services rendered in accordance with the terms and conditions of the contract, within 30 (thirty) days after receipt of an invoice.

<i>DESCRIPTION OF SERVICE</i>	<b>PRICE (ALL APPLICABLE TAXES INCLUDED )</b>	<b>COMPLETION DATE</b>	<b>B-BBEE STATUS LEVEL OF CONTRIBUTION</b>	<b>MINIMUM THRESHOLD FOR LOCAL PRODUCTION AND CONTENT (if applicable)</b>

4. I confirm that I am duly authorised to sign this contract.

SIGNED AT ..... ON .....

NAME (PRINT) .....

SIGNATURE .....

OFFICIAL STAMP

.....

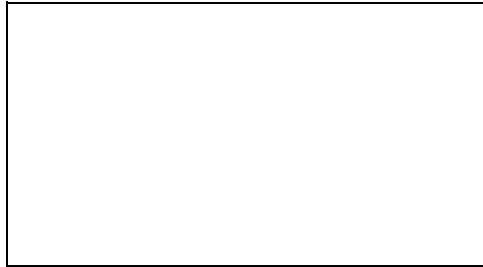
A large empty rectangular box intended for an official stamp.

WITNESSES

1 .....

....

2 .....

**CONTRACT FORM - SALE OF GOODS/WORKS**

**THIS FORM MUST BE FILLED IN DUPLICATE BY BOTH THE SUCCESSFUL BIDDER (PART 1) AND THE SELLER (PART 2). BOTH FORMS MUST BE SIGNED IN THE ORIGINAL SO THAT THE SUCCESSFUL BIDDER AND THE SELLER WOULD BE IN POSSESSION OF ORIGINALLY SIGNED CONTRACTS FOR THEIR RESPECTIVE RECORDS.**

**PART 1 (TO BE FILLED IN BY THE BIDDER)**

13. I hereby undertake to purchase all or any of the goods and/or works described in the attached bidding documents from (name of institution)..... in accordance with the requirements stipulated in (bid number)..... at the price/s quoted. My offer/s remain binding upon me and open for acceptance by the seller during the validity period indicated and calculated from the closing time of bid.
  
14. The following documents shall be deemed to form and be read and construed as part of this agreement:
  - (vii) Bidding documents, *viz*
    - Invitation to bid;
    - Tax clearance certificate;
    - Pricing schedule(s);
    - Declaration of interest;
    - Declaration of Bidder's past SCM practices;
    - Special Conditions of Contract;
  - (viii) General Conditions of Contract; and
  - (ix) Other (specify)
  
15. I confirm that I have satisfied myself as to the correctness and validity of my bid; that the price(s) quoted cover all the goods and/or works specified in the bidding documents; that the price(s) cover all my obligations and I accept that any mistakes regarding price(s) and calculations will be at my own risk.
  
16. I accept full responsibility for the proper execution and fulfilment of all obligations and conditions devolving on me under this agreement as the principal liable for the due fulfillment of this contract.

- 17. I undertake to make payment for the goods/works as specified in the bidding documents.
- 18. I declare that I have no participation in any collusive practices with any bidder or any other person regarding this or any other bid.
- 19. I confirm that I am duly authorised to sign this contract.

NAME (PRINT)

.....

CAPACITY

.....

SIGNATURE

.....

NAME OF FIRM

.....

DATE

.....

WITNESSES	
1	.....
.....	

3.

.....

**CONTRACT FORM - SALE OF GOODS/WORKS**

**PART 2 (TO BE FILLED IN BY THE SELLER)**

- 7. I..... in my capacity as..... accept your bid under reference number .....dated.....for the purchase of goods/works indicated hereunder and/or further specified in the annexure(s).
- 8. I undertake to make the goods/works available in accordance with the terms and conditions of the contract.

<b>ITEM NO.</b>	<b>DESCRIPTION</b>	<b>PRICE (ALL APPLICABLE TAXES INCLUDED)</b>		

4. I confirm that I am duly authorized to sign this contract.

SIGNED AT .....ON.....

NAME (PRINT) .....

SIGNATURE .....

OFFICIAL STAMP

WITNESSES

3. ....

4. ....

DATE .....

**DECLARATION OF BIDDER’S PAST SUPPLY CHAIN MANAGEMENT PRACTICES**

- 1 This Municipal Bidding Document must form part of all bids invited.
- 2 It serves as a declaration to be used by municipalities and municipal entities in ensuring that when goods and services are being procured, all reasonable steps are taken to combat the abuse of the supply chain management system.
- 3 The bid of any bidder may be rejected if that bidder, or any of its directors have:
  - a. abused the municipality’s / municipal entity’s supply chain management system or committed any improper conduct in relation to such system;
  - b. been convicted for fraud or corruption during the past five years;
  - c. willfully neglected, reneged on or failed to comply with any government, municipal or other public sector contract during the past five years; or
  - d. been listed in the Register for Tender Defaulters in terms of section 29 of the Prevention and Combating of Corrupt Activities Act (No 12 of 2004).
- 4 **In order to give effect to the above, the following questionnaire must be completed and submitted with the bid.**

Item	Question	Yes	No
4.1	<p>Is the bidder or any of its directors listed on the National Treasury’s Database of Restricted Suppliers as companies or persons prohibited from doing business with the public sector?</p> <p><b>(Companies or persons who are listed on this Database were informed in writing of this restriction by the Accounting Officer/Authority of the institution that imposed the restriction after the <i>audi alteram partem</i> rule was applied).</b></p> <p>The Database of Restricted Suppliers now resides on the National Treasury’s website(<a href="http://www.treasury.gov.za">www.treasury.gov.za</a>) and can be accessed by clicking on its link at the bottom of the home page.</p>	Yes <input type="checkbox"/>	No <input type="checkbox"/>

4.1.1	If so, furnish particulars:		
4.2	Is the bidder or any of its directors listed on the Register for Tender Defaulters in terms of section 29 of the Prevention and Combating of Corrupt Activities Act (No 12 of 2004)? <b>The Register for Tender Defaulters can be accessed on the National Treasury's website (<a href="http://www.treasury.gov.za">www.treasury.gov.za</a>) by clicking on its link at the bottom of the home page.</b>	Yes <input type="checkbox"/>	No <input type="checkbox"/>
4.2.1	If so, furnish particulars:		
4.3	Was the bidder or any of its directors convicted by a court of law (including a court of law outside the Republic of South Africa) for fraud or corruption during the past five years?	Yes <input type="checkbox"/>	No <input type="checkbox"/>
4.3.1	If so, furnish particulars:		
Item	Question	Yes	No
4.4	Does the bidder or any of its directors owe any municipal rates and taxes or municipal charges to the municipality / municipal entity, or to any other municipality / municipal entity, that is in arrears for more than three months?	Yes <input type="checkbox"/>	No <input type="checkbox"/>
4.4.1	If so, furnish particulars:		
4.5	Was any contract between the bidder and the municipality / municipal entity or any other organ of state terminated during the past five years on account of failure to perform on or comply with the contract?	Yes <input type="checkbox"/>	No <input type="checkbox"/>

4.7.1	If so, furnish particulars:
-------	-----------------------------

**CERTIFICATION**

**I, THE UNDERSIGNED (FULL NAME) .....  
 CERTIFY THAT THE INFORMATION FURNISHED ON THIS  
 DECLARATION FORM TRUE AND CORRECT.**

**I ACCEPT THAT, IN ADDITION TO CANCELLATION OF A CONTRACT, ACTION MAY  
 BE TAKEN AGAINST ME SHOULD THIS DECLARATION PROVE TO BE FALSE.**

.....  
**Signature**

.....  
**Date**

.....  
**Position**

.....  
**Name of Bidder**



**CERTIFICATE OF INDEPENDENT BID DETERMINATION**

- 1 This Municipal Bidding Document (MBD) must form part of all bids<sup>1</sup> invited.
  
- 2 Section 4 (1) (b) (iii) of the Competition Act No. 89 of 1998, as amended, prohibits an agreement between, or concerted practice by, firms, or a decision by an association of firms, if it is between parties in a horizontal relationship and if it involves collusive bidding (or bid rigging).<sup>2</sup> Collusive bidding is a *pe se* prohibition meaning that it cannot be justified under any grounds.
  
- 3 Municipal Supply Regulation 38 (1) prescribes that a supply chain management policy must provide measures for the combating of abuse of the supply chain management system, and must enable the accounting officer, among others, to:
  - a. take all reasonable steps to prevent such abuse;
  - b. reject the bid of any bidder if that bidder or any of its directors has abused the supply chain management system of the municipality or municipal entity or has committed any improper conduct in relation to such system; and
  - c. cancel a contract awarded to a person if the person committed any corrupt or fraudulent act during the bidding process or the execution of the contract.
  
- 4 This MBD serves as a certificate of declaration that would be used by institutions to ensure that, when bids are considered, reasonable steps are taken to prevent any form of bid-rigging.
  
- 5 In order to give effect to the above, the attached Certificate of Bid Determination (MBD 9) must be completed and submitted with the bid:

**<sup>1</sup> Includes price quotations, advertised competitive bids, limited bids and proposals.**

**<sup>2</sup> Bid rigging (or collusive bidding) occurs when businesses, that would otherwise be expected to compete, secretly conspire to raise prices or lower the quality of**

**goods and / or services for purchasers who wish to acquire goods and / or services through a bidding process. Bid rigging is, therefore, an agreement between competitors not to compete.**

**CERTIFICATE OF INDEPENDENT BID DETERMINATION**

I, the undersigned, in submitting the accompanying bid:

\_\_\_\_\_

(Bid Number and Description)

in response to the invitation for the bid made by:

\_\_\_\_\_

(Name of Municipality / Municipal Entity)

do hereby make the following statements that I certify to be true and complete in every respect:

I certify, on behalf

of: \_\_\_\_\_ that:

(Name of Bidder)

1. I have read and I understand the contents of this Certificate;
2. I understand that the accompanying bid will be disqualified if this Certificate is found not to be true and complete in every respect;
3. I am authorized by the bidder to sign this Certificate, and to submit the accompanying bid, on behalf of the bidder;
4. Each person whose signature appears on the accompanying bid has been authorized by the bidder to determine the terms of, and to sign, the bid, on behalf of the bidder;
5. For the purposes of this Certificate and the accompanying bid, I understand that the word "competitor" shall include any individual or organization, other than the bidder, whether or not affiliated with the bidder, who:

- (a) has been requested to submit a bid in response to this bid invitation;
- (b) could potentially submit a bid in response to this bid invitation, based on their qualifications, abilities or experience; and
- (c) provides the same goods and services as the bidder and/or is in the same line of business as the bidder

6. The bidder has arrived at the accompanying bid independently from, and without consultation, communication, agreement or arrangement with any competitor. However communication between partners in a joint venture or consortium<sup>3</sup> will not be construed as collusive bidding.
7. In particular, without limiting the generality of paragraphs 6 above, there has been no consultation, communication, agreement or arrangement with any competitor regarding:
  - (a) prices;
  - (b) geographical area where product or service will be rendered (market allocation)
  - (c) methods, factors or formulas used to calculate prices;
  - (d) the intention or decision to submit or not to submit, a bid;
  - (e) the submission of a bid which does not meet the specifications and conditions of the bid; or
  - (f) bidding with the intention not to win the bid.
8. In addition, there have been no consultations, communications, agreements or arrangements with any competitor regarding the quality, quantity, specifications and conditions or delivery particulars of the products or services to which this bid invitation relates.
9. The terms of the accompanying bid have not been, and will not be, disclosed by the bidder, directly or indirectly, to any competitor, prior to the date and time of the official bid opening or of the awarding of the contract.

**<sup>3</sup> Joint venture or Consortium means an association of persons for the purpose of combining their expertise, property, capital, efforts, skill and knowledge in an activity for the execution of a contract.**

10. I am aware that, in addition and without prejudice to any other remedy provided to combat any restrictive practices related to bids and contracts, bids that are suspicious will be reported to the Competition Commission for investigation and possible imposition of administrative penalties in terms of section 59 of the Competition Act No 89 of 1998 and or may be reported to the National Prosecuting Authority (NPA) for criminal investigation and or may be restricted from conducting business with the public sector for a period not exceeding ten (10) years in terms of the Prevention and Combating of Corrupt Activities Act No 12 of 2004 or any other applicable legislation.

.....  
Signature Date

.....  
Position Name of Bidder

**GENERAL CONDITIONS OF CONTRACT (National Treasury)**  
GOVERNMENT PROCUREMENT: General Conditions of Contract  
TABLE OF CLAUSES

- 1. Definitions
- 2. Application
- 3. General
- 4. Standards
- 5. Use of contract documents and information inspection
- 6. Patent Rights
- 7. Performance security
- 8. Inspections, tests and analyses
- 9. Packing
- 10. Delivery and documents
- 11. Insurance
- 12. Transportation
- 13. Incidental Services

14. Spare parts
15. Warranty
16. Payment
17. Prices
18. Variation orders
19. Assignment
20. Subcontracts
21. Delays in the supplier's performance
22. Penalties
23. Termination for default
24. Anti-dumping and countervailing duties and rights
25. Force Majeure
26. Termination for insolvency
27. Settlement of Disputes
28. Limitation of Liability
29. Governing language
30. Applicable law
31. Notices
32. Taxes and duties
33. Transfer of contracts
34. Amendments of contracts
35. Prohibition of restrictive practices

## 1 DEFINITIONS

The following terms shall be interpreted as indicated:

- 1.1 "Closing time" means the date and hour specified in the bidding documents for the receipt of bids.
- 1.2 "Contract" means the written agreement entered into between the purchaser and the supplier, as recorded in the contract form signed by the parties, including all attachments and appendices thereto and all documents incorporated by reference therein.
- 1.3 "Contract price" means the price payable to the supplier under the contract for the full and proper performance of his contractual obligations.
- 1.4 "Contract practice" means the offering, giving, receiving, or soliciting of anything of value to influence the action of a public official in the procurement process or in contract execution.
- 1.5 "Countervailing duties" are imposed in cases where an enterprise abroad is subsidized by its government and encouraged to market its products internationally.
- 1.6 "Country of origin" means the place where the goods were mined, grown or produced or from which the services are supplied. Goods are produced when, through manufacturing, processing or substantial and major assembly of components, a commercially recognized

- new product results that is substantially different in basic characteristics or in purpose or utility from its components.
- 1.7 “Day” means calendar day.
  - 1.8 “Delivery” means delivery in compliance of the conditions of the contract or order.
  - 1.9 “Delivery ex stock” means immediate delivery directly from stock actually on hand.
  - 1.10 “Delivery into consignees store or to his site” means delivered and unloaded in the specified store or depot or on the specified site in compliance with the conditions of the contract or order, the supplier bearing all risks and charges involved until the goods are so delivered and a valid receipt is obtained.
  - 1.11 “Dumping” occurs when a private enterprise abroad market its goods on own initiative in the RSA at lower prices than that of the country of origin and which have the potential to harm the local industries in the RSA.
  - 1.12 “Force majeure” means an event beyond the control of the supplier and not involving the supplier’s fault or negligence and not foreseeable. Such events may include, but is not restricted to, acts of the purchaser in its sovereign capacity, wars or revolutions, fires, floods, epidemics, quarantine restrictions and freight embargoes.
  - 1.13 “Fraudulent practice” means a misrepresentation of facts in order to influence a procurement process or the execution of a contract to the detriment of any bidder, and includes collusive practice among bidders (prior to or after bid submission) designed to establish bid prices at artificial non-competitive levels and to deprive the bidder of the benefits of free and open competition.
  - 1.14 “GCC” mean the General Conditions of Contract.
  - 1.15 “Goods” means all of the equipment, machinery, and/or other materials that the supplier is required to supply to the purchaser under the contract.
  - 1.16 “Imported content” means that portion of the bidding price represented by the cost of components, parts or materials which have been or are still to be imported (whether by the supplier or his subcontractors) and which costs are inclusive of the costs abroad, plus freight and other direct importation costs such as landing costs, dock dues, import duty, sales duty or other similar tax or duty at the South African place of entry as well as transportation and handling charges to the factory in the Republic where the goods covered by the bid will be manufactured.
  - 1.17 “Local content” means that portion of the bidding price, which is not included in the imported content provided that local manufacture does take place.
  - 1.18 “Manufacture” means the production of products in a factory using labour, materials, components and machinery and includes other related value-adding activities.
  - 1.19 “Order” means an official written order issued for the supply of goods or works or the rendering of a service.
  - 1.20 “Project site”, where applicable, means the place indicated in bidding documents.
  - 1.21 “Purchaser” means the organization purchasing the goods.
  - 1.22 “Republic” means the Republic of South Africa.
  - 1.23 “SCC” means the Special Conditions of Contract.
  - 1.24 “Services” means those functional services ancillary to the supply of the goods, such as transportation and any other incidental services, such as installation, commissioning,



provision of technical assistance, training, catering, gardening, security, maintenance and other such obligations of the supplier covered under the contract.

- 1.25 “Supplier” means the successful bidder who is awarded the contract to maintain and administer the required and specified service(s) to the State.
- 1.26 “Tort” means in breach of contract.
- 1.27 “Turnkey” means a procurement process where one service provider assumes total responsibility for all aspects of the project and delivers the full end product / service required by the contract.
- 1.28 “Written” or “in writing” means hand-written in ink or any form of electronic or mechanical writing.

## GOVERNMENT PROCUREMENT: General Conditions of Contract

### 2. **Application**

2.1 These general conditions are applicable to all bids, contracts and orders including bids for functional and professional services (excluding professional services related to the building and construction industry), sales, hiring, letting and the granting or acquiring of rights, but excluding immovable property, unless otherwise indicated in the bidding documents.

2.2 Where applicable, special conditions of contract are also laid down to cover specific goods, services or works.

2.3 Where such special conditions of contract are in conflict with these general conditions, the special conditions shall apply.

### 3. **General**

3.1 Unless otherwise indicated in the bidding documents, the purchaser shall not be liable for any expense incurred in the preparation and submission of a bid. Where applicable a nonrefundable fee for documents may be charged.

3.1 Invitations to bid are usually published in locally distributed news media and on the municipality/municipal entity website.

### 4. **Standards**

4.1 The goods supplied shall conform to the standards mentioned in the bidding documents and specifications.

### 5. **Use of contract documents and information inspection**

5.1 The supplier shall not, without the purchaser’s prior written consent, disclose the contract, or any provision thereof, or any specification, plan, drawing, pattern, sample, or information furnished by or on behalf of the purchaser in connection therewith, to any person other than a person employed by the supplier in the performance of the contract. Disclosure to any such employed person shall be made in confidence and shall extend only so far as may be necessary for purposes of such performance.

5.2 The supplier shall not, without the purchaser’s prior written consent, make use of any document or information mentioned in GCC clause 5.1 except for purposes of performing the contract.

5.3 Any document, other than the contract itself mentioned in GCC clause 5.1 shall remain the property of the purchaser and shall be returned (all copies) to the purchaser on completion of the supplier’s performance under the contract if so required by the purchaser.

5.4 The supplier permit the purchaser to inspect the supplier's records relating to the performance of the supplier and to have them audited by auditors appointed by the purchaser, if so required by the purchaser.

#### GOVERNMENT PROCUREMENT: General Conditions of Contract

### 6. **Patent Rights**

6.1 The supplier shall indemnify the purchaser against all third-party claims of infringement of patent, trademark, or industrial design rights arising from use of the goods or any part thereof by the purchaser.

6.2 When a supplier developed documentation / projects for the municipality / municipal entity, the intellectual, copy and patent rights or ownership of such documents or projects will best in the municipality / municipal entity.

### 7. **Performance security**

7.1 Within thirty (30) days of receipt of the notification of contract award, the successful bidder shall furnish to the purchaser the performance security of the amount specified in SCC.

7.2 The proceeds of the performance security shall be payable to the purchaser as compensation for any loss resulting from the supplier's failure to complete his obligations under the contract.

7.3 The performance security shall be denominated in the currency of the contract or in a freely convertible currency acceptable to the purchaser and shall be in one of the following forms:

a) A bank guarantee or an irrevocable letter of credit issued by a reputable bank located in the purchaser's country or abroad, acceptable to the purchaser, in the form provided in the bidding documents or another form

b) A cashier's or certified cheque.

7.4 The performance security will be discharged by the purchaser and returned to the supplier not later than thirty (30) days following the date of completion of the supplier's performance obligations under the contract, including any warranty obligations, unless otherwise specified.

### 8. **Inspections, tests and analyses**

8.1 All pre-bidding testing will be for the account of the bidder.

8.2 If it is a bid condition that goods to be produced or services to be rendered should at any stage be subject to inspections, tests and analyses, the bidder or contractor's premises shall be open, at all reasonable hours, for inspection by a representative of the purchaser or organization acting on behalf of the purchaser.

8.3 If there are no inspection requirements indicated in the bidding documents and no mention is made in the contract, but during the contract period it is decided that inspections shall be carried out, the purchaser shall itself make the necessary arrangements, including payment arrangements with the testing authority concerned.

8.4 If the inspections, tests and analyses referred to in clauses 8.2 and 8.3 show the goods to be in accordance with the contract requirements, the cost of the inspections, tests and analyses shall be defrayed by the purchaser.

8.5 Where the goods or services referred to in clauses 8.2 and 8.3 do not comply with the contract requirements, irrespective of whether such goods or services are accepted or not, the cost in connection with these inspections, tests or analyses shall be defrayed by the supplier.

- 8.6 Goods and services which are referred to in clauses 8.2 and 8.3 and which do not comply with the contract requirements may be rejected.
- 8.7 Any contract goods may on or after delivery be inspected, tested or analyzed and may be rejected if found not to comply with the requirements of the contract. Such rejected goods shall be held at the cost and risk of the supplier who shall, when called upon, remove them with goods, which do comply with the requirements of the contract. Failing such removal the rejected goods shall be returned at the suppliers cost and risk. Should the supplier fail to provide the substitute goods forthwith, the purchaser may, without giving the supplier further opportunity to substitute the rejected goods, purchase such goods as may be necessary at the expense of the supplier.
- 8.8 The provisions of clauses 8.4 and 8.7 shall not prejudice the right of the purchaser to cancel the contract on account of a breach of the conditions thereof, or to act in terms of Clause 22 of GCC.

9. **Packing**

- 9.1 The supplier shall provide such packing of the goods as is required to prevent their damage or deterioration during transit to their final destination, as indicated in the contract. The packing shall be sufficient to withstand, without limitation, rough handling during transit and exposure to extreme temperatures, salt and precipitation during transit, and open storage. Packing, case size weights shall take into consideration, where appropriate, the remoteness of the goods' final destination and the absence of heavy handling facilities at all points in transit.
- 9.2 The packing, marking, and documentation within and outside the packages shall comply strictly with such special requirements as shall be expressly provided for in the contract, including additional requirements, if any, and in any subsequent instructions ordered by the purchaser.

10. **Delivery and documents**

- 10.1 Delivery of the goods and arrangements for shipping and clearance obligations shall be made by the supplier in accordance with the terms specified in the contract.

11. **Insurance**

- 11.1 The goods supplied under the contract shall be fully insured in a freely convertible currency against loss or damage incidental to manufacture or acquisition, transportation, storage and delivery in the manner specified.

12. **Transportation**

- 12.1 Should a price other than an all-inclusive delivered price be required, this shall be specified.

GOVERNMENT PROCUREMENT: General Conditions of Contract

13. **Incidental Services**

- 13.1 The supplier may be required to provide any or all of the following services, including additional services, if any:
- a) Performance or supervision of on-site assembly and/or commissioning of the supplied goods;
  - b) Furnishing of tools required for assembly and/or maintenance of the supplied goods;
  - c) Furnishing of a detailed operations and maintenance manual for each appropriate unit of the supplied goods;

- d) Performance or supervision or maintenance and/or repair of the supplied goods, for a period of time agreed by the parties, provided that this service shall not relieve the supplier of any warranty obligations under this contract; and
- e) Training of the purchaser's personnel, at the supplier's plant and/or on-site, in assembly, start-up, operation, maintenance, and/or repair of the supplied goods.

13.2 Prices charged by the supplier for incidental services, if not included in the contract price for the goods, shall be agreed upon in advance by the parties and shall not exceed the prevailing rates charged to other parties by the supplier for similar services.

#### 14. **Spare parts**

14.1 As specified, the supplier may be required to provide any or all of the following materials, notifications, and information pertaining to spare parts manufactured or distributed by the supplier:

a) Such spare parts as the purchaser may elect to purchase from the supplier, provided that this election shall not relieve the supplier of any warranty obligations under the contract; and; b) In the event of termination of production of the spare parts:

- i. Advance notification to the purchaser of the pending termination, in sufficient time to permit the purchaser to procure needed requirements; and
- ii. Following such termination, furnishing at no cost to the purchaser, the blueprints, drawings, and specifications of the spare parts, if requested.

#### 15. **Warranty**

15.1 The supplier warrants that the goods supplied under the contract are new, unused, of the most recent or current models and those they incorporate all recent improvements in design and materials unless provided otherwise in the contract. The supplier further warrants that all goods supplied under this contract shall have no defect, arising from design, materials, or workmanship (except when the design and/or material is required by the purchaser's specifications) or from any act or omission of the supplier, that may develop under normal uses of the supplied goods in the conditions prevailing in the country of final destination.

15.2 This warranty shall remain valid for twelve (12) months after the goods, or any portion thereof as the case may be, have been delivered to and accepted at the final destination indicated in the contract, or for eighteen (18) months after the date of shipment from the port or place of loading in the source country, whichever period concludes earlier, unless specified otherwise.

15.3 The purchaser shall promptly notify the supplier in writing of any claims arising under this warranty.

15.4 Upon receipt of such notice, the supplier shall, within the period specified and with all reasonable speed, repair or replace the defective goods or parts thereof, without costs to the purchaser.

#### GOVERNMENT PROCUREMENT: General Conditions of Contract

15.5 If the supplier, having been notified, fails to remedy the defect(s) within the period specified, the purchaser may proceed to take such remedial action as may be necessary, at the supplier's risk and expense and without prejudice to any other rights which the purchaser may have against the supplier under the contract.

#### 16. **Payment**

16.1 The method and conditions of payment to be made to the supplier under this contract shall be specified.

16.2 The supplier shall furnish the purchaser with an invoice accompanied by a copy of the delivery note and upon fulfillment of other obligations stipulated in the contract.

16.3 Payments shall be made promptly by the purchaser, but in no case later than thirty (30) days after submission of an invoice or claim by the supplier. 16.4 Payment will be made in Rand unless otherwise stipulated.

#### **17. Prices**

17.1 Prices charged by the supplier for goods delivered and services performed under the contract shall not vary from the prices quoted by the supplier in his bid, with the exception of any price adjustments authorized or in the purchaser's request for bid validity extension, as the case may be.

#### **18. Variation orders**

18.1 In cases where the estimated value of the envisaged changes in purchase does not vary more than 15% of the total value of the original contract, the contractor may be instructed to deliver the goods or render the services as such. In cases of measurable quantities, the contractor may be approached to reduce the unit price, and such offers may be accepted provided that there is no escalation in price.

#### **19. Assignment**

19.1 The supplier shall not assign, in whole or in part, its obligations to perform under the contract, except with the purchaser's prior written consent.

#### **20. Subcontracts**

20.1 The supplier shall notify the purchaser in writing of all subcontracts awarded under this contract if not already specified in the bid. Such notification, in the original bid or later, shall not relieve the supplier from any liability or obligation under the contract.

#### **21. Delays in the supplier's performance**

21.1 Delivery of the goods and performance of services shall be made by the supplier in accordance with the time schedule prescribed by the purchaser in the contract.

21.2 If at any time during performance of the contract, the supplier or its subcontractor(s) should encounter conditions impeding timely delivery of the goods and performance of services, the supplier shall promptly notify the purchaser on writing of the fact of the delay, its likely duration and its cause(s). as soon as practicable after receipt of the supplier's notice, the purchaser shall evaluate the situation and may at his discretion extend the supplier's time for performance, without the imposition of penalties, in which case the extension shall be ratified by the parties by amendment of contract.

21.3 The right is reserved to procure outside of the contract shall quantities or to have minor essential services executed if any emergency arises, the supplier's point of supply is not situated at or near the place where the goods are required, or the supplier's services are not readily available.

21.4 Except as provided under GCC Clause 25, a delay by the supplier in the performance of its delivery obligations shall render the supplier liable to the imposition of penalties, pursuant to GCC Clause 22, unless an extension of time is agreed upon pursuant to GCC Clause 22.2 without the application of penalties.

21.5 Upon any delay beyond the delivery period in the case of a goods contract, the purchaser shall, without cancelling the contract, be entitled to purchase goods of a similar quality and up to the same quantity in substitution of the goods not supplied in conformity with the

contract and to return any goods delivered later at the supplier's expense and risk, or to cancel the contract and buy such goods as may be required to complete the contract and without prejudice to his other rights, be entitled to claim damages from the supplier.

## **22. Penalties**

22.1 Subject to GCC Clause 25, if the supplier fails to deliver any or all of the goods or to perform the services within the period(s) specified in the contract, the purchaser shall, without prejudice to its other remedies under the contract, deduct from the contract price, as a penalty, a sum calculated on the delivered price of the delayed goods or unperformed services using the current prime interest rate calculated for each day of the delay until actual delivery or performance. The purchaser may also consider termination of the contract pursuant to the GCC Clause 23.

## **GOVERNMENT PROCUREMENT: General Conditions of Contract**

### **23. Termination for default**

23.1 The purchaser, without prejudice to any other remedy for breach of contract, by written notice of default sent to the supplier, may terminate this contract in whole or in part:

- a) If the supplier fails to deliver any or all of the goods within the period(s) specified in the contract, or within any extension thereof granted by the purchaser pursuant to GCC Clause 21.2;
- b) If the supplier fails to perform any other obligation(s) under the contract; or
- c) If the supplier, in the judgment of the purchaser, has engaged in corrupt or fraudulent practices in competing for or in executing the contract.

23.2 In the event the purchaser terminates the contract in whole or in part, the purchaser may procure, upon such terms and in such manner, as it deems appropriate, goods, works or services similar to those undelivered, and the supplier shall be liable to the purchaser for any excess costs for such similar goods, works or services. However, the supplier shall continue performance of the contract to the extent not terminated.

23.3 Where the purchaser terminates the contract in whole or in part, the purchaser may decide to impose a restriction penalty on the supplier by prohibiting such supplier from doing business with the public sector for a period not exceeding 10 years.

23.4 If a purchaser intends imposing a restriction on a supplier or any person associated with the supplier, the supplier will be allowed a time period of not more than fourteen (14) days to provide reasons why the envisaged restriction should not be imposed. Should the supplier fail to respond within the stipulated fourteen (14) days the purchaser may regard the supplier as having no objection and proceed with the restriction?

23.5 Any restriction imposed on any person by the purchaser will, at the discretion of the purchaser, also be applicable to any other enterprise or any partner, manager, director or other person who wholly or partly exercises or exercised or may exercise control over the enterprise of the first-mentioned person, and with which enterprise or person the first-mentioned person, is or was in the opinion of the purchaser actively associated.

23.6 If a restriction is imposed, the purchaser must, within five (5) working days of such imposition, furnish the National Treasury, with the following information:

- i. The name and address of the supplier and / or person restricted by the purchaser; ii. The date of commencement of the restriction

- iii. The period of restriction; and
- iv. The reasons for the restriction.

These details will be loaded in the National Treasury's central database of suppliers or persons prohibited from doing business with the public sector.

#### GOVERNMENT PROCUREMENT: General Conditions of Contract

23.7 If a court of law convicts a person of an offence as contemplated in sections 12 or 13 of the Prevention and Combating of Corrupt Activities Act, No. 12 of 2004, the court may also rule that such person's name be endorsed on the Register for Tender Defaulters. When a person's name be endorsed on the Register, the person will be prohibited from doing business with the public sector for a period not less than five years and not more than 10 years. The National Treasury is empowered to determine the period of restriction and each case will be dealt with on its own merits. According to section 32 of the Act the Register must be open to the public. The Register can be perused on the National Treasury website.

#### 24. **Anti-dumping and countervailing duties and rights**

24.1 When, after the date of bid, provisional payments are required, or anti-dumping or countervailing duties are imposed or the amount of a provisional payment or anti-dumping or countervailing right is increased in respect of any dumped or subsidized import, the State is not liable for any amount so required or imposed, or for the amount of any such increase. When, after the said date, such a provisional payment is no longer required or any such anti-dumping or countervailing right is abolished, or where the amount of such provisional payment or any such right is reduced, any such favorable difference shall on demand be paid forthwith by the supplier to the purchaser or the purchaser may deduct such amounts from moneys (if any) which may otherwise be due to the supplier in regard to goods or services which he delivered or rendered, or is to deliver or render in terms of the contract or any other contract or any other amount which may be due to him.

#### 25. **Force Majeure**

25.1 Notwithstanding the provisions of GCC Clause 22 and 23, the supplier shall not be liable for forfeiture of its performance security, damages, or termination for default if and to the extent that his delay in performance or other failure to perform his obligations under the contract is the result of an event of force majeure.

25.2 If a force majeure situation arises, the supplier shall promptly notify the purchaser in writing of such condition and the cause thereof. Unless otherwise directed by the purchaser in writing, the supplier shall continue to perform its obligations under the contract as far as is reasonably practical, and shall seek all reasonable alternative means for performance not prevented by the force majeure event.

#### 26. **Termination for insolvency**

26.1 The purchaser may at any time terminate the contract by giving written notice to the supplier if the supplier becomes bankrupt or otherwise insolvent. In this event, termination will be without compensation to the supplier, provided that such termination will not prejudice or affect any right of action or remedy, which has accrued or will accrue thereafter to the purchaser.

GOVERNMENT PROCUREMENT: General Conditions of Contract

27. **Settlement of Disputes**

- 27.1 If any dispute or difference of any kind whatsoever arises between the purchaser and supplier in connection with or arising out of the contract, the parties shall make every effort to resolve amicably such dispute or difference by mutual consultation.
- 27.2 If, after thirty (30) days, the parties have failed to resolve their dispute or difference by such mutual consultation, then either the purchaser or the supplier may give notice to the other party of his intention to commence with mediation. No mediation in respect of this matter may be commenced unless such notice is given to the other party.
- 27.3 Should it not be possible to settle a dispute by means of mediation, it may be settled in a South African court of law.

GOVERNMENT PROCUREMENT: General Conditions of Contract

- 27.4 Notwithstanding any reference to mediation and/or court proceedings herein,
- a) the parties shall continue to perform their respective obligations under the contract unless they otherwise agree; and
- b) the purchaser shall pay the supplier any monies due the supplier for goods delivered and / or services rendered according to the prescripts of the contract.

28. **Limitation of Liability**

- 28.1 Except in cases of criminal negligence or wilful misconduct, and in the case of infringement pursuant to Clause 6;
- a) the supplier shall not be liable to the purchaser, whether in contract, tort, or otherwise, for any indirect or consequential loss or damage, loss of use, loss of production, or loss of profits or interest costs, provided that this exclusion shall not apply to any obligation of the supplier to pay penalties and/or damages to the purchaser; and
- b) -the aggregate liability of the supplier to the purchaser, whether under the contract, in tort or otherwise, shall not exceed the total contract price, provided that this limitation shall not apply to the cost of repairing or replacing defective equipment.

29. **Governing language**

- 29.1 The contract shall be written in English. All correspondence and other documents pertaining to the contract that is exchanged by the parties shall also be written in English.

GOVERNMENT PROCUREMENT: General Conditions of Contract

30. **Applicable law**

- 30.1 The contract shall be interpreted in accordance with South African laws, unless otherwise specified.

31. **Notices**

- 31.1 Every written acceptance of a bid shall be posted to the supplier concerned by registered or certified mail and any other notice to him shall be posted by ordinary mail to the address furnished in his bid or to the address furnished in his bid or to the address notified later by him in writing and such posting shall be deemed to proper service of such notice.



31.2 The time mentioned in the contract documents for performing any act after such aforesaid notice has been given, shall be reckoned from the date of posting of such notice.

32. **Taxes and duties**

32.1 A foreign supplier shall be entirely responsible for all taxes, stamp duties, license fees, and other such levies imposed outside the purchaser's country.

32.2 A local supplier shall be entirely responsible for all taxes, duties, license fees, etc. incurred until delivery of the contracted goods to the purchaser.

32.3 No contracts shall be concluded with any bidder whose tax matters are not in order. Prior to the award of a bid SARS must have certified that the tax matters of the preferred bidder are in order.

32.4 No contract shall be concluded with any bidder whose municipal rates and taxes and municipal services charges are in arrears.

GOVERNMENT PROCUREMENT: General Conditions of Contract

33. **Transfer of contracts**

33.1 The contractor shall not abandon, transfer, cede assign or sublet a contract or part thereof without the written permission of the purchaser.

34. **Amendment of contracts**

34.1 No agreement to amend or vary contract or order or the conditions, stipulation or provisions thereof shall be valid and of any force unless such agreement to amend or vary is entered into in writing and signed by the contracting parties. Any waiver of the requirement that the agreement to amend or vary shall be in writing, shall also be in writing.

GOVERNMENT PROCUREMENT: General Conditions of Contract

35. **Prohibition of restrictive practices**

35.1 In terms of section 4 (1) (b) (iii) of the Competition Act No. 89 of 1998, as amended, an agreement between, or concerted practice by, firms, or a decision by an association of firms, is prohibited if it is between parties in a horizontal relationship and if a bidder(s) is / are or a contractor(s) was / were involved in collusive bidding.

35.2 If a bidder(s) or contractor(s) based on reasonable grounds or evidence obtained by the purchaser has / have engaged in the restrictive practice referred to above, the purchaser may refer the matter to the Competition Commission for investigation and possible imposition of administrative penalties as contemplated in section 59 of the Competition Act No 89 of 1998. 35.3 If a bidder(s) or contractor(s) has / have been found guilty by the Competition Commission of the restrictive practice referred to above, the purchaser may, in addition and without prejudice to any other remedy provided for, invalidate the bid(s) for such item(s) offered, and / or terminated the contract in whole or part, and / or restrict the bidder(s) or contractor(s) from conducting business with the public sector for a period not exceeding ten (10) years and / or claim damages from the bidder(s) or contractor(s) concerned.

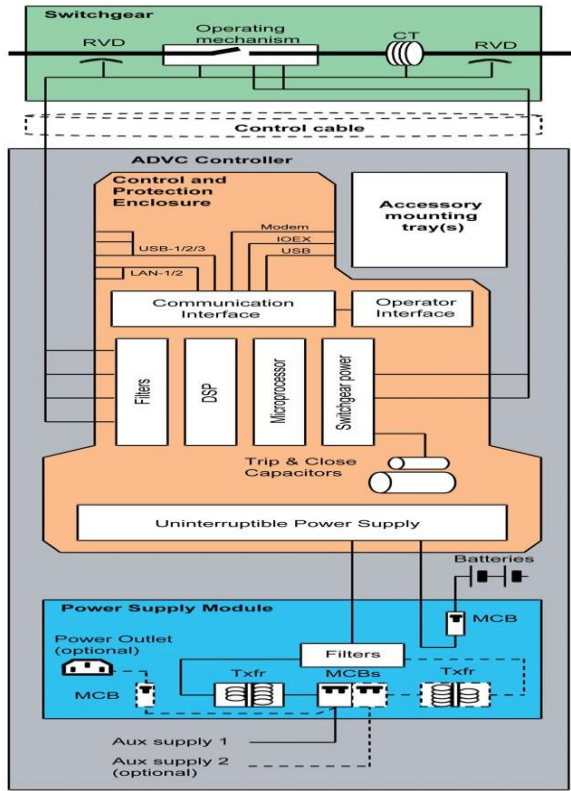

ADVC Controller block diagram

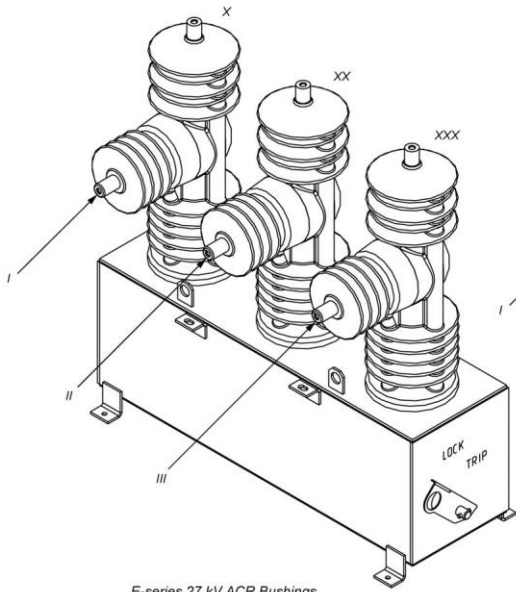

E-series 27 kV ACR Bushings

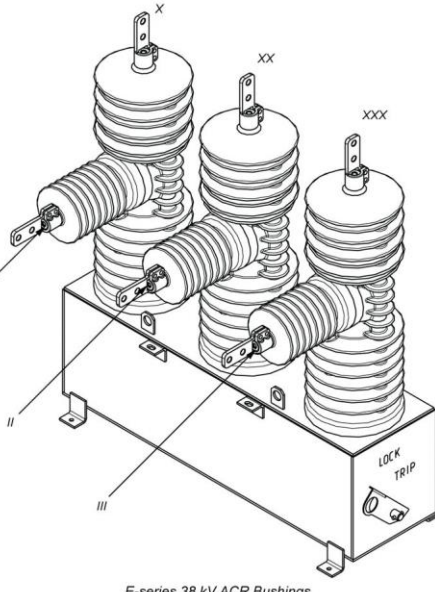

E-series 38 kV ACR Bushings

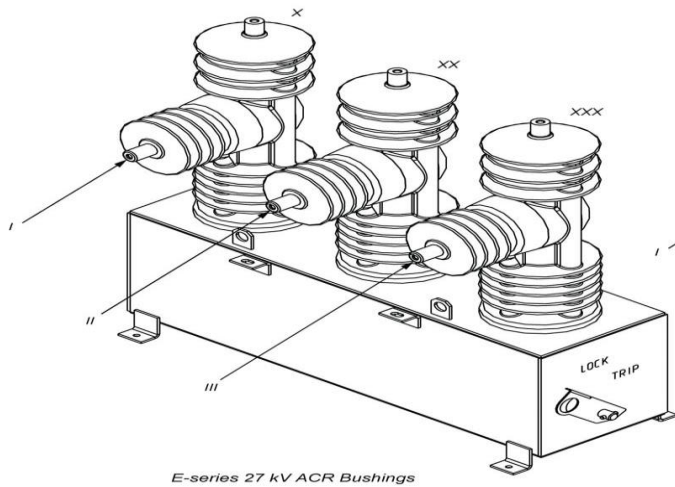

E-series 27 kV ACR Bushings

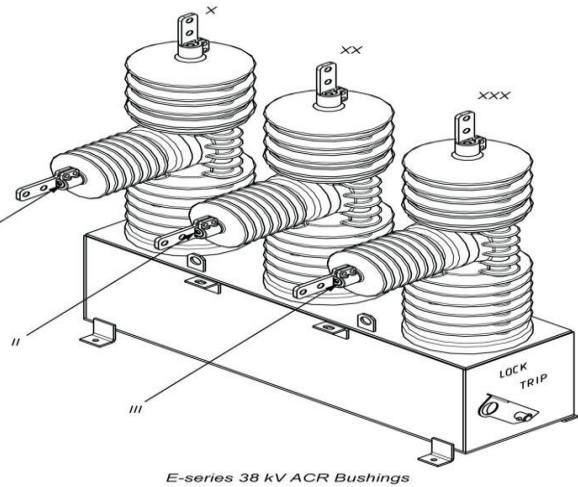

E-series 38 kV ACR Bushings

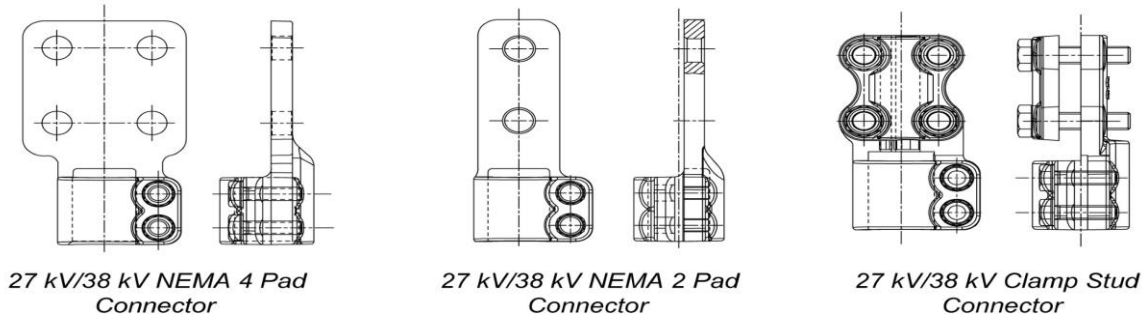

Either one of the above three connectors are required in 6 quantity or recloser.

NOTE: Conductor stems of E-series switchgear are plated with silver. Silver plating can get tarnished due to atmospheric conditions. If such tarnish (black or brown) is seen at the time of installation, then remove tarnish from the conductor by following appropriate procedure before assembling of any of the above connector on the conductors to have a proper joint.

- Bird guards:

The two types of bird guards are suitable for the three types of connectors. Three quantity of source side and three quantity of load side are required for recloser.

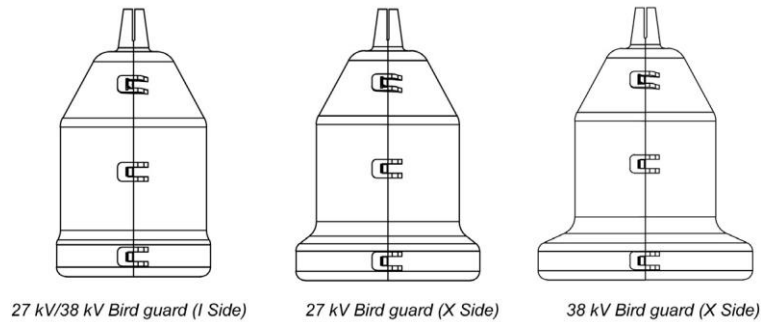

There are three types of mounting brackets that can be used. Either one of these which are required in one quantity per recloser.

- 11 kV/33 kV mounting bracket assembly
- 11 kV/33 kV mounting bracket for wooden pole (through holes mounting)
- 11kV/33 kV substation mounting bracket

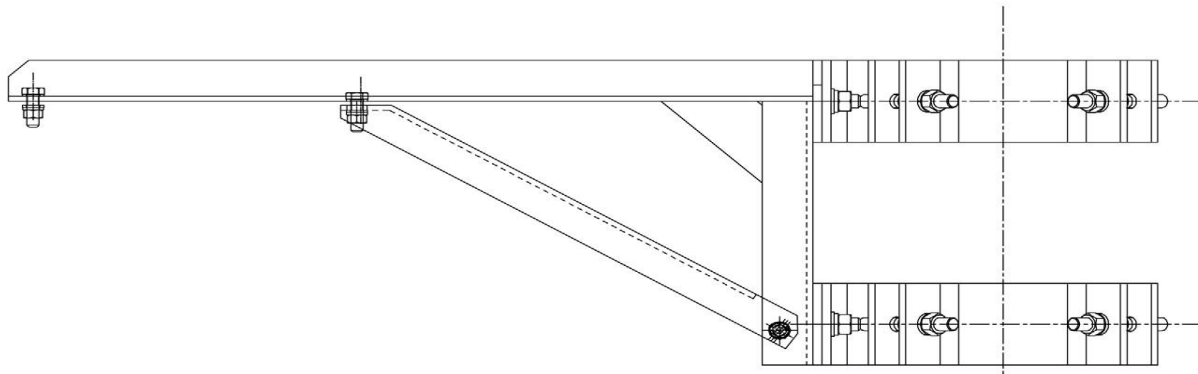
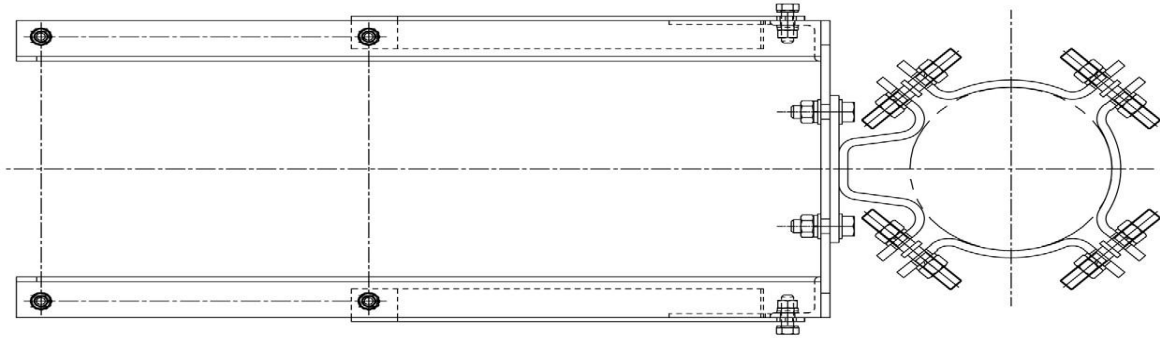

*27 kV/38 kV Mounting bracket assembly  
(Same mounting bracket for end and center mounting)*

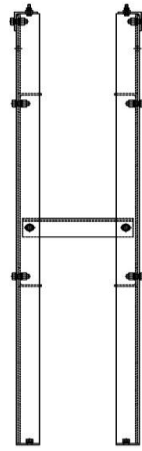
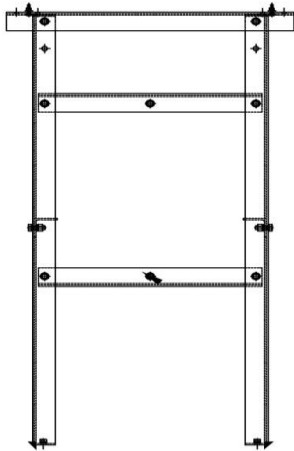
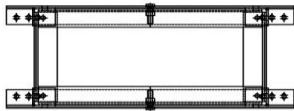

*27 kV /38 kV Substation mounting bracket*

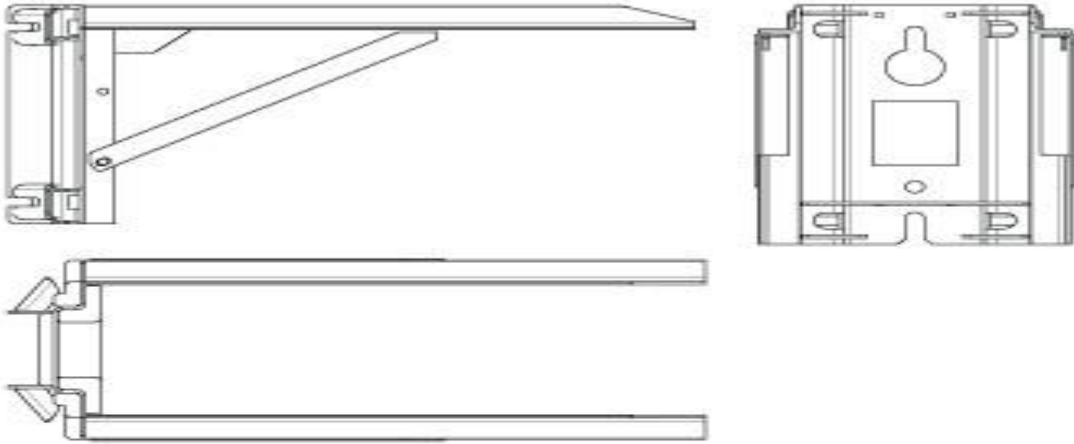

*27 kV/38 kV mounting bracket for wooden pole (through holes mounting)  
(Same mounting bracket for end and center mounting)*



*27 kV/38 kV Pole Clamp Band (if required)*

- Surge Arresters:

Two surge arrester mounting brackets (load and source) are required in one quantity or recloser for mounting six surge arresters.

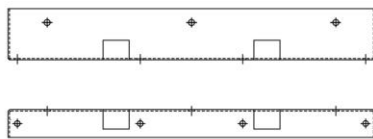

*27 kV Surge arrester mounting bracket load*

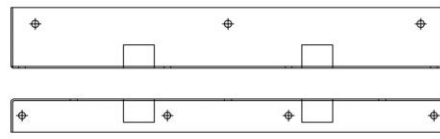

*38 kV Surge arrester mounting bracket load*

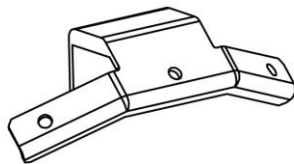

*27 kV/38 kV Surge arrester mounting bracket Source*

- Control Cable:

For more details, refer to figure Control Cable Service Drawing

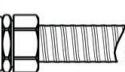
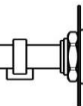
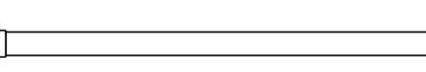

Control Cubicle End

Recloser End